



**Electrolux**  
PROFESSIONAL

**Modular Cooking Range Line  
900XP 800mm Gas Fry Top,  
Smooth Brushed Chrome Plate**

ITEM # \_\_\_\_\_

MODEL # \_\_\_\_\_

NAME # \_\_\_\_\_

SIS # \_\_\_\_\_

AIA # \_\_\_\_\_

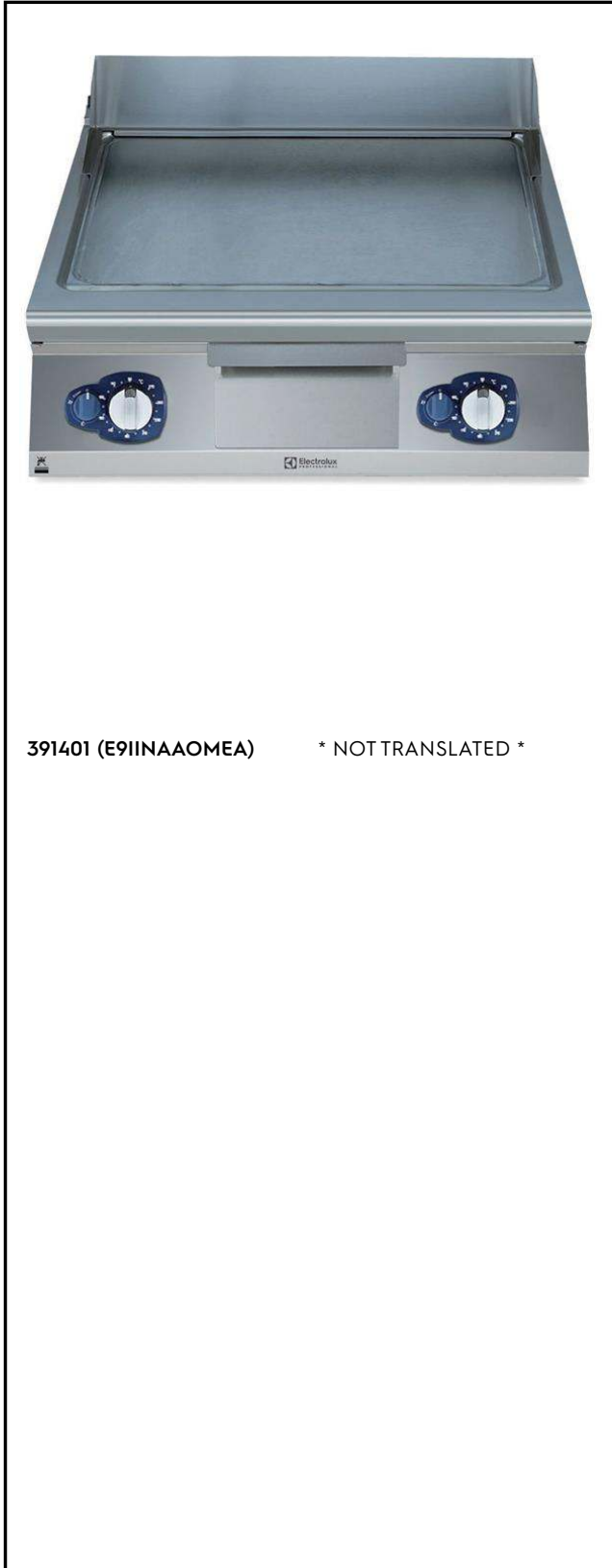

391401 (E9I1NAAOMEA) \* NOT TRANSLATED \*

**Main Features**

- Unit to be mounted on open base cupboards, bridging supports or cantilever systems.
- Large drain hole on cooking surface permits the draining of fat into large 1,5 liter collector placed under the cooking surface.
- Stainless steel high splash guards on the rear and sides of cooking surface. Splash guards can be easily removed for cleaning and are dishwasher-safe.
- Piezo spark ignition with thermostatic valve for added safety.
- Units have separate controls for each half module of the cooking surface.
- The special design of the control knob system guarantees against water infiltration.
- IPX5 water protection.
- Temperature range from 90° up to 270°C.
- Rough brushed chrome surface is highly resistant to scratches and facilitates cleaning operations at the end of the day.
- Scraper for smooth plate included as standard.
- Suitable for countertop installation.

**Construction**

- Unit is 930 mm deep to give a larger working surface area.
- All exterior panels in Stainless Steel with Scotch Brite finishing.
- AISI 304 stainless steel worktop, 2mm thick.
- Model has right-angled side edges to allow flush fitting joints between units, eliminating gaps and possible dirt traps.
- Cooking surface 15mm thick brushed chrome for optimum grilling results and ease of use.
- Cooking surface completely smooth.

**Included Accessories**

- 1 of Scraper for smooth plate fry tops PNC 164255
- 1 of Stopper for fry top with horizontal plate PNC 206296

**Optional Accessories**

- Scraper for smooth plate fry tops PNC 164255
- Junction sealing kit PNC 206086
- Draught diverter with 150mm diameter PNC 206132
- Matching ring for flue condenser PNC 206133
- 4 wheels, 2 swivelling with brake (700/900XP). It is mandatory to install with base supports for feet/wheels. PNC 206135
- Support for bridge type system, 800mm PNC 206137
- Support for bridge type system, 1000mm PNC 206138
- Support for bridge type system, 1200mm PNC 206139

APPROVAL: \_\_\_\_\_



Experience the Excellence  
www.electroluxprofessional.com

- |   |            |                          |
|---|------------|--------------------------|
| • Support for bridge type system, 1400mm  | PNC 206140 | <input type="checkbox"/> |
| • Support for bridge type system, 1600mm  | PNC 206141 | <input type="checkbox"/> |
| • Flue condenser for 1 module, 150 mm diameter  | PNC 206246 | <input type="checkbox"/> |
| • Stopper for fry top with horizontal plate   | PNC 206296 | <input type="checkbox"/> |
| • Chimney upstand, 800mm  | PNC 206304 | <input type="checkbox"/> |
| • BACK HANDRAIL 800 MM - MARINE   | PNC 206308 | <input type="checkbox"/> |
| • BACK HANDRAIL 1200 MM - MARINE  | PNC 206309 | <input type="checkbox"/> |
| • Grease/oil kit container for 700 line frytops (half and module) and 900 line frytops (module) | PNC 206346 | <input type="checkbox"/> |
| • Chimney grid net, 400mm   | PNC 206400 | <input type="checkbox"/> |
| • - NOT TRANSLATED -  | PNC 206455 | <input type="checkbox"/> |
| • - NOT TRANSLATED -  | PNC 206467 | <input type="checkbox"/> |
| • Side handrail-right/left hand   | PNC 216044 | <input type="checkbox"/> |
| • Frontal handrail 800mm  | PNC 216047 | <input type="checkbox"/> |
| • Frontal handrail 1200mm   | PNC 216049 | <input type="checkbox"/> |
| • Frontal handrail 1600mm   | PNC 216050 | <input type="checkbox"/> |
| • Water drain for full module fry tops  | PNC 216153 | <input type="checkbox"/> |
| • Large handrail - portioning shelf, 800mm  | PNC 216186 | <input type="checkbox"/> |
| • 2 side covering panels for top, d=900mm   | PNC 216278 | <input type="checkbox"/> |
| • Pressure regulator for gas units  | PNC 927225 | <input type="checkbox"/> |
| <b>Recommended Detergents</b>   |            |                          |
| • *NOT TRANSLATED*  | PNC 0S2292 | <input type="checkbox"/> |

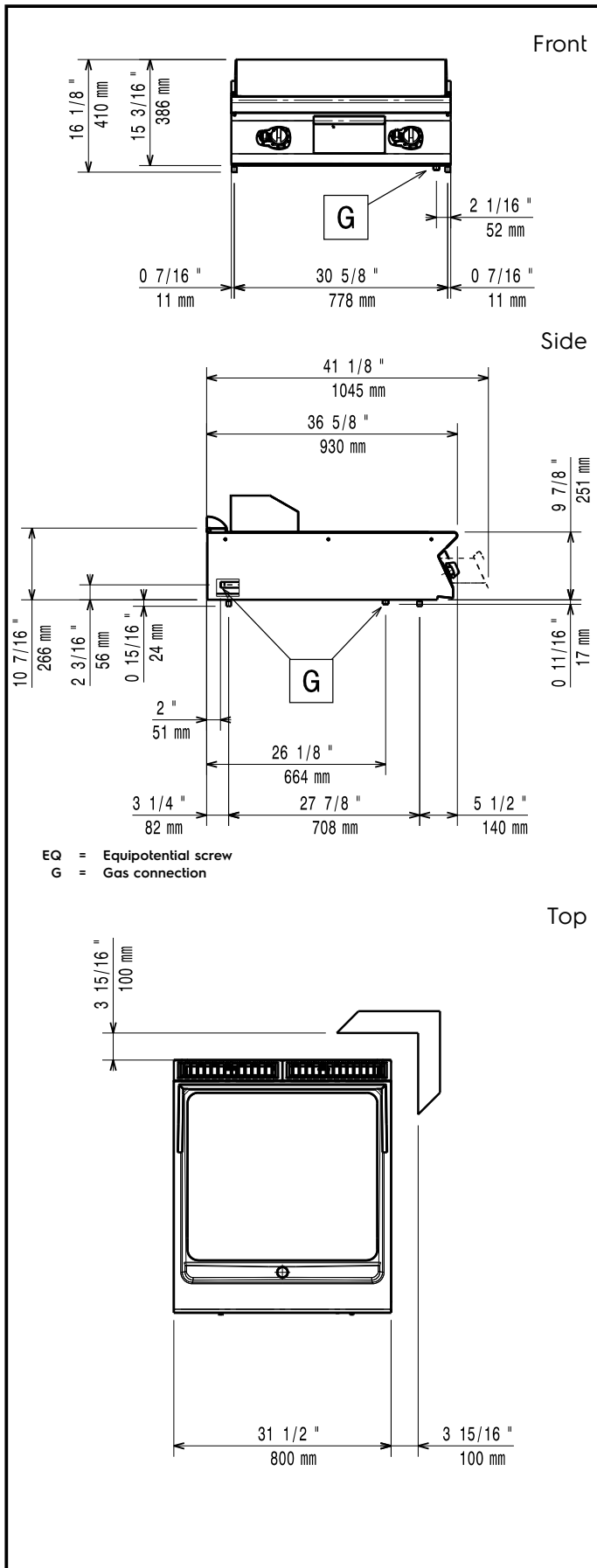

### Gas

Gas Power:	20 kW
Standard gas delivery:	Natural Gas G20 (20mbar)
Gas Type Option:	LPG; Natural Gas
Gas Inlet:	1/2"

### Key Information:

Working Temperature MIN:	90 °C
Working Temperature MAX:	270 °C
External dimensions, Width:	800 mm
External dimensions, Depth:	930 mm
External dimensions, Height:	250 mm
Net weight:	105 kg
Shipping weight:	102 kg
Shipping height:	580 mm
Shipping width:	1010 mm
Shipping depth:	860 mm
Shipping volume:	0.5 m <sup>3</sup>
Cooking surface width:	730 mm
Cooking surface depth:	700 mm

If appliance is set up or next to or against temperature sensitive furniture or similar, a safety gap of approximately 150 mm should be maintained or some form of heat insulation fitted.